

RCA

Wireless

Speakers

with 900 MHz Transmitter

Radio Frequency

900

M H z



Freedom From Wires

listen *anywhere* in your home

W S P 2 0 0

INTRODUCTION

Congratulations on the purchase of your new WSP200 Wireless Stereo Speaker System. This System uses the latest 900 MHz High Frequency Radio Signal that can easily travel through walls, floors, ceilings or partitions to allow the finest stereo sound reproduction.

You can use your Speakers almost anywhere in and around your home or, for outdoor activities, just place them in the location of your choice. There is no need to worry about cable connection between the transmitter and Speakers. It is totally wireless!

Simply adjust the Volume and Tone Controls of the Speakers to your favorite levels, sit back and enjoy music/sound programs from your Compact Disc, TV, Hi-Fi Systems or Portable CD Player or Cassette/Radio.

A NOTE TO THE AUDIOPHILE

With any sound system, the quality of the music is only as good as the source. In today's recording industry, there is a great variation in both the quality and clarity of music soundtracks.

Although CDs are digital in format, many are still reproductions of original analog recordings. As a result, some recordings (even some CDs) have a fairly high noise level that when amplified produces undesirable background static or hiss. This type of static tends to be more noticeable in some easy-listening or classical music recordings, particularly those pieces that have relatively quiet passages and/or prolonged orchestral pauses.

In order to combat this problem, the WSP200 incorporates a state of the art filtering system that eliminates inherent background static without, in any way, compromising the dynamic range of the Speakers.

The result of this technological breakthrough means that you, the listener, can enjoy dynamic static-free music in an unlimited number of indoor and outdoor settings... without the need for wires to transmit the audio signal.

CONTROL LOCATIONS

TRANSMITTER

- 1) LED Indicator (Power ON)
- 2) Power OFF Switch and Channel Selector
- 3) AUDIO IN Jack (L) - Connect to Music Source
- 4) AUDIO IN Jack (R) - Connect to Music Source
- 5) DC Input Jack

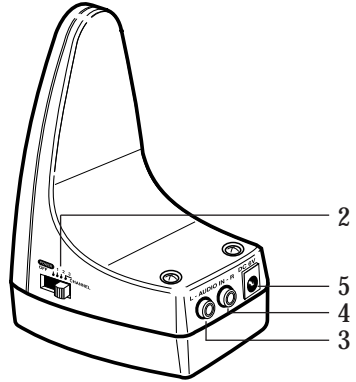
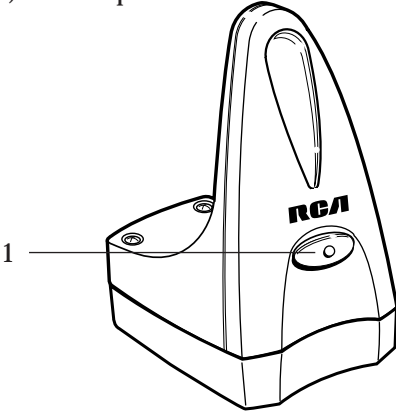

SPEAKER

- 6) Frequency Channel Selector
- 7) Tone Control Knob
- 8) Power OFF and Volume Control Knob
- 9) DC Input Jack
- 10) MODE Switch (To Select Left/Mono or Right Channel)
- 11) Battery Compartment

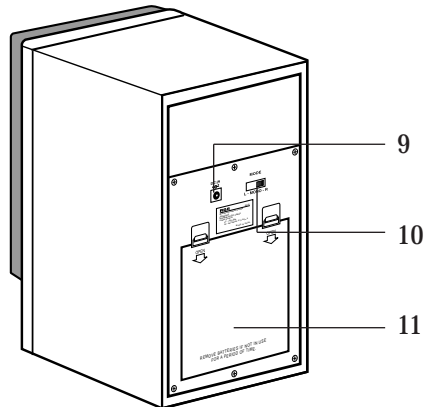
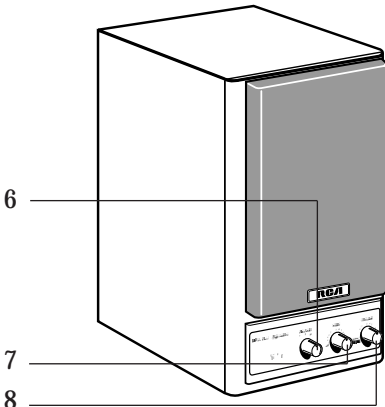

INSTALLING THE TRANSMITTER

You need to properly set up the Transmitter to send a wireless signal to the Speakers. There are two things you must do. First, provide power to the Transmitter, and second, connect the Transmitter to the Audio Source.

1) CONNECTING POWER

(A) DC OPERATION

Your Transmitter is supplied with a Battery Tray. Insert four (4) x AA Alkaline batteries (not supplied) to the battery slot as indicated. Attach the battery tray to the bottom of the Transmitter unit. Be sure to insert the three plastic locks of the battery tray into the openings of the transmitter base, then slide to the front for firm attachment.

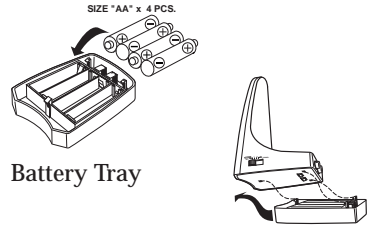

(B) AC OPERATION

Your system is supplied with one 600 mA AC Adapter. Insert the plug of the AC adapter in to the DC Jack at the rear of the Transmitter, then plug the other end of the AC Adapter in to a conveniently located electrical wall outlet.

You are recommended to use the AC Adapter as often as possible, as this is still the most economical power source!

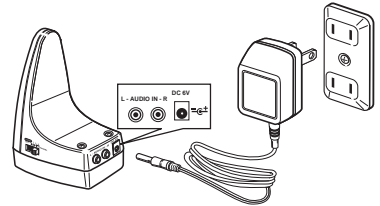

2) CONNECTING TO YOUR AUDIO SOURCE

- Connect one end of the supplied patch cord to the Transmitter's Left (WHITE) and Right (RED) AUDIO IN Jacks.
- Then connect the other end of the patch cord to the Audio Sources Left (WHITE) and Right (RED) AUDIO OUT Jacks.

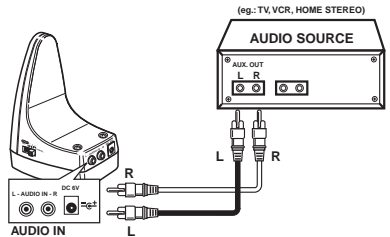

INSTALLING A SPEAKER

CONNECTING POWER

(A) DC OPERATION (with optional BP200SP

Battery Pack sold on page 11)

- Open the battery cover located at the back of the Speaker unit. Insert the battery making sure the side with the contacts (located on the top edge) is inserted to make contact with the coil springs inside the compartment. Push the battery all the way in until you feel resistance from the coil springs inside the compartment. Replace the battery cover making certain the cover is secure prior to moving the Speaker.

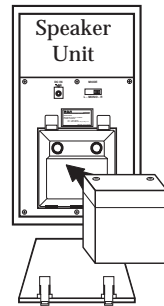

Note: Be sure the battery cover is secure - a falling battery could cause personal injury or damage to equipment.

(B) AC OPERATION

- Insert the power cord of the large sized 1300 mA AC Adapter (provided) into the DC IN Jack located at the back of the Speaker unit.
- Plug the other end of the AC Adapter into a conveniently located electrical wall outlet.

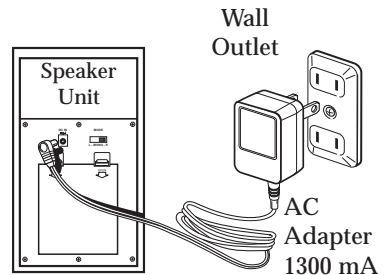

(C) MODE SWITCH

- For normal stereo use, designate one Speaker as LEFT channel and the other as RIGHT channel. Simply set one Speaker to "L" for Left and one to "R" for RIGHT. If you are using a monaural system, set both speakers to the MONO position (middle).

Follow the same steps, as completed above, for the other Speaker.

OPERATION

Follow these steps to obtain maximum listening performance

- 1) Make sure that your Transmitter and Speakers are set up according to the procedures given in this manual.
- 2) Turn on your Audio Source.
- 3) Switch the Transmitter to a Frequency Channel (Channel 1, 2, or 3) that has no interference.

Refer to CHANNEL SELECT below for Precision Frequency Lock-In Tuning.

- 4) Rotate the CHANNEL Knob on the front of the Speakers to select the same channel (Channel 1, 2, or 3) selected on the Transmitter.
- 5) Turn ON each Speaker (Left and Right Speakers) by rotating the VOLUME Control Knob. A 'click' will be heard and the Power ON Indicator (Red) will glow, yet when a Strong Transmission Signal is received from the Transmitter, the Red Indicator will turn green.
- 6) Set each Speaker's MODE switch to L (for the Left Stereo Speaker) and R (for the Right Stereo Speaker) or MONO (if your sound source is mono-phonic) as desired.
- 7) Adjust each Speaker's VOLUME Control and Tone Control Knobs to a comfortable listening level to meet your your personal preference.

Be sure to turn off the Speakers and Transmitter when you are not using them.

CHANNEL SELECT

The popular 900 MHZ High Frequency Technology is being widely applied to Mobile Phones, Cordless Telephones and many more items to come. If you receive interference from some of these devices, you might be able to reduce the interference by switching from one channel to another. There are altogether 3 channels in this system. Simply adjust the transmitting frequency from the Transmitter by switching to an appropriate channel, then rotate the Channel Knob of each Speaker to the same channel. When the signal Indicator turns GREEN and good quality sound output can be heard, you have found the proper channel. The built in Phase Locked Loop (PLL) circuit will lock-in the transmitting and receiving frequency to prevent it from drifting. You do not have to fine tune your Speakers constantly in order to be tuned in for good sound reproduction.

BATTERY OPERATION

TRANSMITTER

When the Transmitter is operated by fresh Alkaline batteries (four (4) AA cells-not included) the Transmitter will play for approximately 4-6 hours continuously. Once the battery power begins to decrease, you will hear static sound from the Speakers. This indicates that you have to replace the batteries. If left unattended, transmitter signal will be decreased until the Speaker NOISE MUTE function activates and shuts off all sound to the Speakers. To avoid this, you may use the supplied AC Adapter so that your playing hours will not be interrupted.

SPEAKERS

The Speakers may be powered using the optional BP200SP Battery Pack. This long play battery allows up to 10 hours of continuous play without the need for AC power and may be recharged hundreds of times.

See the back of this instruction book for ordering information.

WARNING: When not using batteries for a long period of time, remove batteries to prevent leakage in the compartment. Always use fresh batteries for replacement.

TROUBLESHOOTING

If you follow all the instructions in this manual, you should have no problems with your WSP200 Wireless Speaker System. However, in case you can not make the system work, please read the TROUBLESHOOTING section carefully. Do not return to your dealer immediately! Check and follow these guides - you probably can resolve your problems without much difficulty.

PROBLEMS

SOLUTIONS

No Sound

Be sure that both Speakers and the Transmitter are properly powered either by the AC Adapter jacks being firmly plugged in OR by fresh Alkaline batteries in the transmitter.

Be sure the Audio Source is turned ON and operating.

Distorted Audio

The Speakers are placed beyond the transmitter's effective range (Approximately 125 feet). You need to bring the Speakers closer to the Transmitter.

The Transmitter is located too close to the screen of your TV set or Computer Monitor (The Screens' magnetic field can cause some interference to the Transmitter).

Other 900 MHz transmissions are being picked up by the Speaker's receiver. (Likely from a nearby 900 MHz cordless telephone). To avoid such interference, change to a new Frequency Channel for the Speakers and the Transmitter.

The Batteries on your sound source are too low and should be replaced.

Check the Battery Levels of your Transmitter and Speakers. The batteries may be exhausted and need to be replaced or recharged (if using the BP200SP for the speakers).

Background Noise or Hiss

If you have reversed some of the operation procedures (as given on page 5, 1st paragraph Points 1 through 7) so that the Speakers are turned on first, followed by the Transmitter and finally transmitting music from your sound source, some noticeable background noise/hiss can be heard. This is rather normal, as it is merely noise generated from the Pilot Signal. When High Quality music is transmitted through the Transmitter, the Pilot Signal will cease and this background hiss will disappear.

SPECIFICATIONS

TRANSMITTER

Operating Frequency	912 - 914MHz Channel 1: 911.950 MHz Channel 2: 912.925 MHz Channel 3: 913.900 MHz
Power Sources	a) AC Adapter (AC 120/60 Hz~DC 6V 600mA) Supplied b) DC four (4) x AA 6V Alkaline Batteries (Not Included)
Transmitter Dimensions	6" (H) x 3 1/4" (W) x 4 3/8" (D)

RECEIVER SPEAKER(S)

Output Power	16 Watts RMS (8 Watts per Channel)
Receiving Frequency	911.9 - 9.13.9 MHz
Signal to Noise Ratio	55 dB
Channel Separation.	30 dB
Distortion	< 2%
Operating Range.	125 Feet
Speaker Elements	2" Tweeter, 5" Woofer
Phase Locked Loop (PLL)	Digital
Automatic Noise Mute Function	Standard
Speaker Dimensions	11" (H) x 6 1/2" (W) x 8 3/4" (D)
Weight (Transmitter & Receiver Speakers)	15.25 lbs

Specifications are typical; individual units may vary.
Specifications are subject to change for improvement without notice.

RCA ACCESSORIES

The following RCA accessories are available through your RCA dealer or:

ORDER BY PHONE:

Have your Visa, MasterCard or Discover Card ready and call the toll-free number listed below.

This number should only be used to place orders.

1-800-338-0376

ORDER BY MAIL:

Complete order form on page 11 and mail to:

**RCA Accessories
PO Box 8419
Ronks, PA 17573**

D918 SURGE PROTECTOR PLUS

Power surges can enter and destroy your valuable equipment from many sources - cable, phone lines, satellite dishes or electrical connections. Guard your vulnerable equipment against potential damage from power surges or other electrical disturbances.

Features include:

- 3-Way Surge Protection
- 8 Outlets plus Coaxial, Phone & AC Line
- \$10,000 Equipment Guarantee
- Lifetime Warranty



D918
\$**49⁹⁵**†

RCUSAT1 UNIVERSAL REMOTE

Universal Remote Controls 4 Devices, TV, VCR, Satellite or Cable Box, and Audio System

Features include:

- Universal DSS and DBS Compatibility
- Menu and Guide Controls
- Picture-In-Picture Controls
- Code Search For Easy Programming



RCUSAT1
\$**29⁹⁵**†

BP200SP OPTIONAL BATTERY PACK

The BP200SP Battery Pack allows up to 10 hours of continuous play without the need for AC Power. Great for using your Speakers in your yard or on your balcony or patio - where AC power may not be readily available.

Features Include:

- May be charged hundreds of times
- 12V, 4.5 Amp - hour Nominal
- Maintenance-free
- No "memory effect"



BP200SP
\$39⁹⁵ † per unit

ORDER FORM

Name _____

Address _____

City _____ State _____ Zip _____

Day Time Phone Number _____

Money Order Enclosed Check Enclosed

Credit Card: Visa MasterCard Discover

Card Number

- - -

Expires: ____/____/____

Signature _____

ITEM	PRICE	QTY	TOTAL
D918 Surge Protector	\$49.95		
RCUSAT1 Universal Satellite Remote	\$29.95		
BP200SP Battery Pack	\$39.95		
Add Applicable Sales Tax			
Include Post & Handling			\$5.00
Total Amount of Order			

† Tax, Shipping & Handling, Charges Apply © 1997 Thomson Consumer Electronics, Inc.
 Trademark(s) ® Registered Marca(s) Registrada(s)

ONE YEAR LIMITED WARRANTY

Thomson Consumer Electronics, Inc. warrants that for one year from the date of purchase this product is free from defects in material and workmanship. If the item is defective within that period, return it at your expense to the dealer from whom it was purchased together with proof of purchase for replacement. The exchange unit is under warranty for the remainder of the original product's warranty period. This warranty excludes defects or damage due to misuse, abuse, neglect or acts of God, including but not limited to lightning damage. The foregoing represents Thomson's sole obligation under this warranty.

This warranty gives you specific legal rights, and you may have other rights which vary from state to state. For purchases outside the United States, contact your dealer for warranty information.

©Thomson Consumer Electronics, Inc.
Product Exchange Center
32B Spur Drive
El Paso, Texas 79906
1J1513
Trademark(s) ® Registered
Marca(s) Registrada(s)